

AREA: Kkt-N	GRID SQUARE (S): 201E15 201E14	GRID CO-ORDINATES: E N	INITIALS & DATE: SAER 5/12/2012	FEATURE No.: 33491
----------------	--------------------------------------	------------------------------	---------------------------------------	-----------------------

FEATURE TYPE (For example <u>wall</u> staircase, bench, foundation structure, platform etc.): <u>wall</u>	Full extent visible in plan: <input checked="" type="radio"/> YES / NO
--	---

1. Dimensions (in metres)	Length: 6.60m	Width: 0.65m	Height: 0.10m
---------------------------	------------------	-----------------	------------------

2. Type of material(s) used	mudbrick
-----------------------------	----------

3. Coursing (form of construction)	two courses
------------------------------------	-------------

4. Orientation	E-w
----------------	-----

5. Associated collapse	—
------------------------	---

6. Cut & fill feature #'s	—
---------------------------	---

7. Repaired?	—
--------------	---

8. Associated floors	
----------------------	--

9. Surface treatments? E.g. <u>plaster</u> paint, mouldings	33492
---	-------

10. Size of one component	0.38m X 0.18m
---------------------------	---------------

11. Bonding material	sandy silt
----------------------	------------

12. Excavated	Yes <input checked="" type="radio"/> / No <input type="radio"/> Not excavated
---------------	---

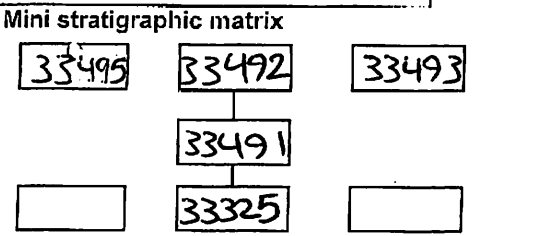

Abuts: <33325> Same as:  
 Abutted by: <33495> <33493> Associated features:  
 Bonded into:  
 Contiguous with:

Discussion and interpretation:  
 E-w mud brick wall about the western face of wall <33325> and abutted by E-w mud brick door jamb <33495> and coated by desert tafla plaster (33492) the wall itself formed From the northern face.  
 the southern boundary of spaces (11307), (11308), (11311) and the northern limit of spaces (11301) and (11303)  
 It built from two courses the northern side has stretcher and the southern side headers.

Remember: do not just draw the architectural feature in isolation. Show how it relates to surrounding features and include details of surface treatments, repairs/modifications/damage, bonding material(s), and associated cuts. Annotate all aspects of the feature or use a Drawing Key. Measurements must be included for all aspects of the feature and surrounding features.

Sketch Plan - Include grid co-ordinates, North arrow, and elevations.

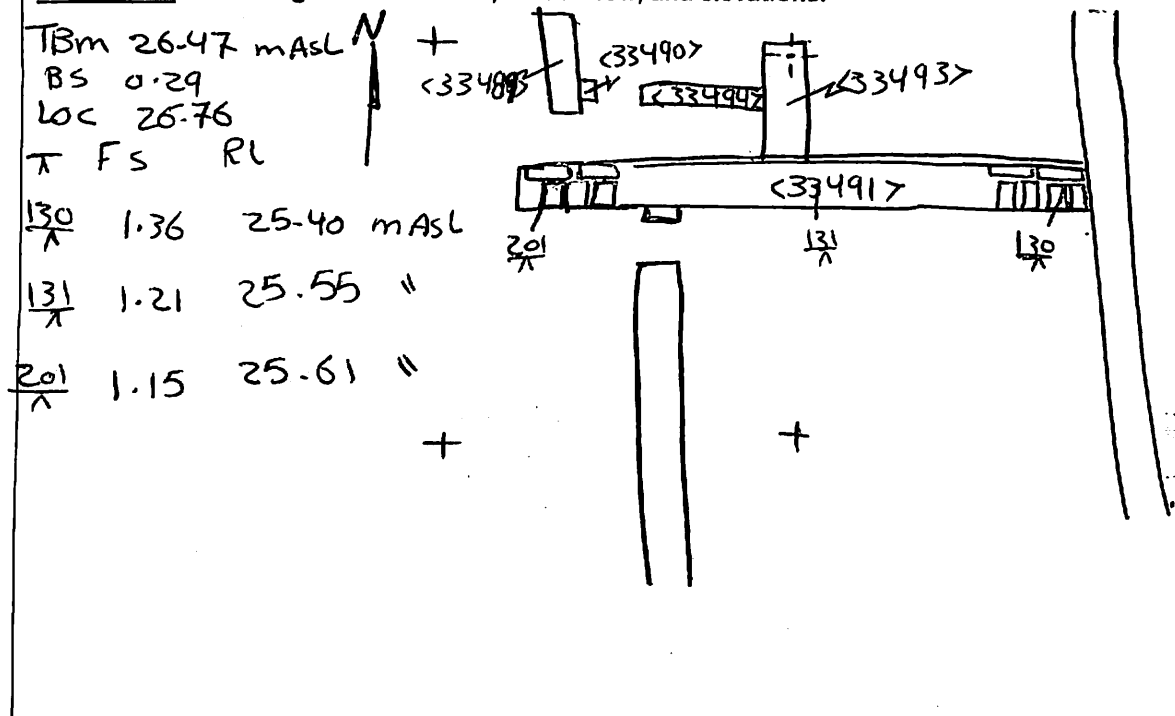

201E15  
 + N99365.00  
 - E500205.00  
 + N99360.00  
 - E500205.00

Profile Sketch - State direction the elevation of the feature being drawn is facing e.g. 'West Facing Elevation of Feature .... If feature was drawn in section then include the grid co-ordinates and elevations.

Drawing No.'s: 2012-2	Photo No.'s: 512729, 512730
Space No.: 11307, 11308, 11311, 11301 11303	Structure No.: house(B)
Matrix Group:	Matrix Phase: 5
Samples taken:	